

AN INTELLIGENT BLOCKCHAIN-IOT MODEL FOR TRANSPARENT AND TAMPER-RESISTANT AGRICULTURAL DATA

Muhammad Awais Khan ¹, Muhammad Mehdi Raza ², Abdul Wahab ³
Muhammad Rizwan Amin ⁴

¹ Department of Computer Science, Bahauddin Zakariya University, Multan, Pakistan.

² Department Masters in Human Centered Design Pace University, New York.

^{3,4} Department of Software Engineering Faculty of Information Technology, The University of
Lahore, Lahore, Pakistan.

DOI: <https://doi.org/>

Keywords: IoT, blockchain, sensor data, cotton, smart contracts.

Article History

Received on 20 Oct 2025

Accepted on 20 Nov 2025

Published on 24 Dec 2025

Copyright @Author

Corresponding Author: *

Awais55samad@gmail.com

Abstract

With the rapid advancement of communication technologies, the Internet of Things (IoT) has evolved from an emerging concept into a mature ecosystem, leading to a massive increase in data generation, transmission, and processing. As a result, managing large-scale, geographically distributed IoT devices has become increasingly complex, especially when real-world performance and reliability are required. Most existing IoT management platforms rely on centralized architectures, which introduce several limitations, including vulnerability to cyber-attacks, single points of failure, and restricted scalability. Moreover, ensuring secure data access while complying with governmental and regulatory privacy requirements remains a critical challenge. To address these concerns, this study proposes a block chain-integrated IoT sensor system designed to enhance the security and privacy of sensed data. The primary objective is to provide IoT device owners with a practical application that maintains a transparent, tamper-resistant record of sensor information while enabling simple and controlled access to connected devices. The system incorporates essential IoT sensor framework functionalities, such as real-time data monitoring and regulated interactions between users and devices. Business logic and access policies are enforced through smart contracts, which define predefined rules and operational conditions within the application.

The proposed framework is validated through a real-world IoT prototype implemented using a NodeMCU microcontroller, along with configured network access permissions. Performance

evaluation is conducted using multiple metrics to assess efficiency, scalability, and feasibility in resource-constrained IoT environments. The system is experimentally tested in cotton field conditions, where automated irrigation is implemented to improve water utilization. Experimental results demonstrate that integrating block chain with IoT substantially enhances data transparency, system security, and operational efficiency in agricultural management, offering a robust and practical solution for modern smart farming applications.

INTRODUCTION

The IoT is continuously growing as more data is sent and received and more things are connected. Such a rise in the data flow has led to the necessity of the improved control of devices utilized globally in real-life scenarios [1-5]. Currently, agriculture remains a vital sector in Pakistan since it supports the population and is an essential component of the country's economy. It is a foundation industry that impacts multiple spheres of human activity and business initiatives. On this note, 'Cotton' referred to as 'White Gold' can be considered to be one of the most significant crops in the country, occupying a strategic position and exercising significant control on the country's agriculture domain [6,7].

Several of today's IoT frameworks are known to use a centralized data processing and storage system as pointed out [8-15]. However, these frameworks have some issues like the problem of imitation attacks, which is explained [16-21]. These are the challenges that need to be overcome in order to improve data availability. Manufacturing, medicine, and agriculture industries are commonly using IoT technology for M2M communication as stated in the study [22]. Nevertheless, many difficulties remain in the practical application of current IoT technologies. In the last few years, the application of blockchain technology has been popular due to its security and transparency advantages which have been described above [23-30]. Rising as a suitable solution for Industry 4.0, blockchain also has the ability to integrate various devices and time stamp multiple data feeds [31].

Food production is going through changes and is faced with different issues related to the environment and society. Most of the farmers are still practicing conventional farming systems and do not directly access the markets and hence the conservation of scarce natural resources such as land and water is difficult. Novelty in the diets, preferences of the customers, and climatic conditions are other factors that make it difficult to deliver good quality food to the customers. Traditional farming methods have caused negative impacts such as deforestation, water and soil problems that call for improved techniques that conserve the environment and increase yield [32].

In the modern context Pakistan's agricultural geography signifies a lot because it serves the purpose of food security and boosts the economy of the country. It therefore remains to be the dominant profession which is interlinked with our cultures and business world [33]. Making up about 18. Agriculture constitutes 4% of the Pakistan's gross domestic product and it plays a vital role in the development of the country. Its main objective is to increase production and ensure adequate food for the growing population. Most of the population of Pakistan relies on farming; therefore, to maintain the stability of the economy, the government must work on the improvement of agricultural production.

In Pakistan, monsoon is vital to agriculture since it plays a critical role in the growth of crops. The irregularity of rainfall was what led to the classification of agriculture as “monsoon-dependent,” therefore, mostly depending on rain. The rainy season is from June to October, where more than 75% of the annual precipitation is received. Hence, there is a need to plan well on how water can be utilized in the other eight months of the year [34].

Progressing to general methods is similar to smart agriculture and other field [35-42]. Smart agriculture brings a change in the management of agricultural systems in the face of climate change. It was first launched in 2009 and has been developed further with the help of stakeholders. Created following debates on agricultural policies, it is to take action against climate change and achieve sustainable growth. It uses technologies such as IoT, big data, and cloud computing. To help farmers with information related to the status of fields and crop growth.

Agriculture occupies a special place in the world economy and plays an important role in people’s lives by supplying food grains and materials. It plays an active role in a nation’s economic growth process and is one of the main sources of income affecting the general state of a country’s economy. But the problem still persists that most of the farmers are still using the conventional practices of farming and old methods of food distribution which hampers the productivity rates. These are some of the problems that must be solved and to ensure a revolution in the agricultural industry, the use of IoT, and blockchain technologies are vital [43].

Global warming, diseases, dry weather, and pests affect crop yield, which results in unfavorable consequences. Of all the constraints, pest and diseases have been observed to have the greatest effect on both the total output and crop yield [44]. Regretfully, the yield of cotton keeps on reducing due to inefficient techniques. However, if we pay much attention to the environmental factors, we are able to prevent the spread of diseases, increase production and quality of cotton, promote the healthy growth of the cotton plants and reduce on the usage of chemical fertilizers and pesticides. All this is made possible by the use of the sensor-based system and monitoring of the cotton fields in real time. In this study work, IoT-based system is proposed to monitor the major climate factors like, first one is temperature, second one is humidity, and third, which is also important for cotton production is soil moisturization. The goal is to transmit this sensor data from the source known as Nodes to the destination which is storage/cloud along with the use of blockchain for secure communication. The objective of the study is to incorporate smart contracts into the system to guarantee safe storage of data that cannot be altered. Also, the objective is to ensure that accurate information transfer is achieved throughout the production of the cotton.

1. Related work

In general, the development of IoT (Internet of Things) has brought into focus its importance in different areas, though the problems of security and privacy still remain the major constraints to the use of IoT in agriculture. To overcome these limitations, Blockchain is used for security, privacy, and identification of agricultural data. If Blockchain and IoT are incorporated, the conventional ways of farming can be substituted by decentralized, credible, and non-tamper able systems that could help in uplifting the agriculture domain and improving the supply chain solutions. The presented research [45] focuses on the need for integrating Blockchain and IoT for the development of smart agriculture, suggesting a model to address the sector’s issues and reviewing Blockchain’s roles in agriculture, such as livestock tracking and food supply chain while considering security concerns and future directions.

Monetary exchanges through blockchain technology eliminate third parties; therefore, it is advantageous for AgriChain, which deals with supply chains in the agricultural sector. The use of

blockchain in AgriChain shall ensure faster payment processes, and less intermediaries which are vital for sustainable agriculture supply chain especially in the developing world as is the case of India. Transaction waiting time and confirmation time were well explained in the study [46-53] where the authors used a queueing model to assess the characteristics of AgriChain system.

Due to this, smallholder farmers struggle to make enough income since they are unable to access trusted markets and buyers. The literature [54-58] reviews the use of blockchain to manage risks associated with transactions so that farmers can safely engage in exchanges. Through the use of smart contracts in block chain technology farmers can undertake futures contracts, access cash up front and enhance the market connections hence increasing their income and reducing on financial barriers. This paper shows that the application of the Smart Agricultural Commodity Market platform can prove that blockchain can help farmers and reduce poverty in the agricultural industry. Blockchain, initially developed for the financial world, has the potential to solve non-financial use cases, thus, attracting extensive research in both academia and industries.

In a study, authors [59] incorporated blockchain with novel technologies including fog computing, cloud computing, and machine learning to solve various problems in several domains. In smart agriculture, IoT has played a vital role in automating the systems; however, security and privacy challenges are still prevalent. To overcome these challenges in IoT-enabled smart agriculture systems, a trust model that is based on blockchain technology along with the Ethereum network and smart contracts is proposed [60]. An intelligent agricultural system managed through an Android application is proposed to minimize the use of water in small and medium-sized agricultural fields. Analyzing data privacy and security issues related to IoT applications, an intelligent fuzzy logic system with the blockchain and timely analysis of the network's security is provided. Real-time environmental data is collected by different sensors and the data is stored in an IoT cloud platform, watering schedules are set using intelligent fuzzy logic and for security, the use of block chain is also incorporated. Evaluation (Ting et al., 2022) also proves the system's ability to scale, secure, and effective for multiple users to remotely control and access the system and receive notifications on watering needs. Today, the safety and quality of agricultural products are highly important due to the globalization of production and distribution. Blockchain technology presents a disruptive innovation model for the implementation of traceability and quality assurance in supply chains of agriculture. The authors of study work [61-63] used Ethereum blockchain and smart contracts to present an efficient method to trace the soybean production where the intermediaries are not required and the information is made transparent, accurate, and secure all through the supply chain. The entire process of transactions is documented in the blockchain, which provides the stakeholders with full visibility of the supply chain system. Cotton is a very significant fibre internationally, cultivated in more than hundred places. It is much beloved by plant scientists and they strive to develop new varieties that would meet the requirements of the high-quality production. Since cotton continues to grow, these scientists continue to strive for the top. Also, cotton seeds are used in rubber, animal feed, food, cosmetics, and polymers.

2. Methods and Materials

As for this experiment, the process of developing an IoT-based system is explained. This system includes of hardware for moisturization of the soil, temperature of the air and humidity of the air by using DHT11 sensor, soil moisture sensor and microcontroller board NodeMCU. These hardware devices are described with their respective images in the following:

2.1. DHT-11

This sensor is utilized to measure air temperature and air humidity value. This sensor is readily available in Pakistan at low cost. The sensor is shown in Figure 1. This device is powered by a low power supply voltage ranging from 3 to 5 volts for both the power supply and input/output. It uses a max of 2.5 milliamperes during the data conversion process. It gives humidity readings in the range of 20% to 80% with an accuracy of 5%. Like humidity, it provides temperature measurement from 0 to 50 0C with the precision of 2 0C.

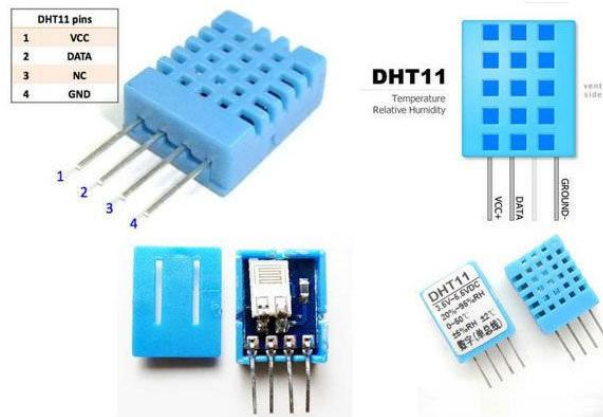

Figure 1: DHT-11 Sensor

2.2. Soil moisture sensor

A soil moisture sensor is not some device connected to an irrigation system. It is the control mechanism that ensures plants receive the proper amount of moisture. The sensor image with pin configuration is presented in Figure 2. It determines the extent to which the soil is wet in the area where root growth is taking place. Then, prior to each watering cycle, it determines whether the soil moisture is sufficient, as per the user’s setting. If it is, then it provides an exemption to the irrigation system.

The matter of the soil moisture is fundamental if for garden or a whole field of plants. It is like the plants’ bloodstream because it determines how they take in nutrients and how they respond to fluctuations in temperature. Besides, when the soil is wet, it helps roots develop well and in a healthy manner. But if things go to extremes, one way or the other, plant growth is affected and even opened to unpleasant company such as soil pathogens.

They are all about determining how much water is idling in the soil. But instead of digging up soil samples and weighing them, these sensors have different stunts.

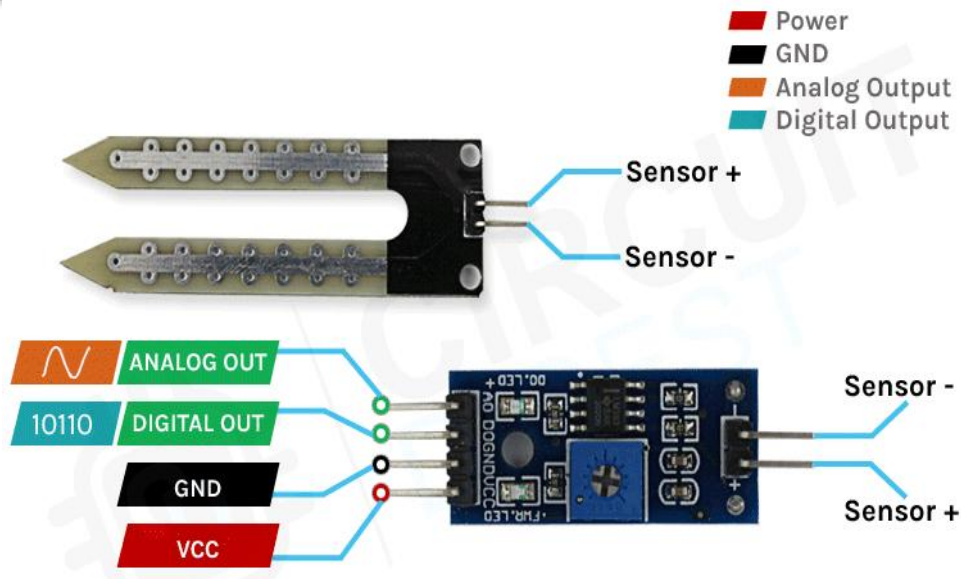

Figure 2: Moisture sensor

2.3. NodeMCU

This device is also called esp8266 and is most famous because it can send data to the internet via Wi-Fi. As depicted in the Figure 3 below, that has the pin names. NodeMCU is an IoT platform which consist of firmware for ESP8266 Wi-Fi System on Chip and hardware that is based on ESP-12 module. This configuration permits a vast number of uses, all of which are coded in Lua scripting language, a decision that is easily understandable given the language's simplicity. The NodeMCU Dev Kit or board uses the ESP8266 Wi-Fi chip which is relatively cheap and supports the TCP/IP protocol by Espresso if Systems. To understand more about the ESP8266, one can go to the ESP8266 WiFi Module. The NodeMCU Dev Kit also has a Version 2 (V2) and the NodeMCU Development Board v1. 0 (Version 2), usually indicated by the black PCB. This microcontroller and development and prototyping board particularly designed for IoT applications, which is containing ESP8266 Wi-Fi transceiver module along with CH340 USB converter chip. The Wi-Fi module supports the 802. 4GHz band with b/g/n standards at 2. 4 GHz, with an embedded TCP/IP stack, 19. Output power of 5 dBm and multiple data interfaces such as UART, HSPI, I2C, I2S, GPIO for Ir Remote Control and PWM. PCB antenna improves the communication link. Also, the board is provided with a micro-USB port and a reset switch, which makes it easy to use. It also supports interpreter for language like LUA and compatible with Arduino IDE.

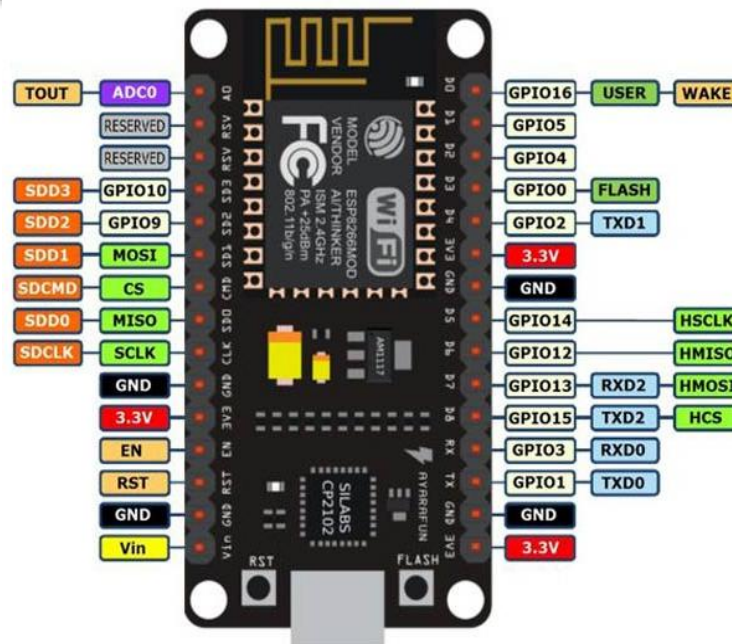

Figure 3: NodeMCU pinout

2.4. Software Description

Arduino IDE is the software used for installing the intended hardware and sensors. It has friendly user interface and is an open-source application. This setup includes all the essentials for working with Arduino projects: There is a text editor to write code, a message area to give feedback, a console to show an output, a toolbar full of buttons, and functions are divided by the menu bar. Its main purpose is to interface it with Arduino hardware for upload of programs and setting up of serial port communication. If you develop your programs using the Arduino Software (IDE), these programs are referred to as sketches. These sketches are created right in the text editor and are named with the extension .ion. The editor has options such as the cut, copy, and find options of the text. The message area is present in order to inform you what is going on during save and export, and at the same time it is the place where any error messages that occur will appear. On the other hand, the console displays text output from the Arduino Software (IDE) which includes detailed errors and other related information.

2.5. Proposed Method with Block Chain integral

The smart contract is a digital self-executing program that contains states, values, addresses, and functions that are needed at the business model layer in a system. Also known as smart contracts, this was proposed by Nick Szabo to eliminate middlemen and to accelerate business models through the use of contracts. Smart contracts are very vital and they are incorporated in a blockchain system. It takes transaction requests as input to perform business logic, request an endorsement from some other peers present in the blockchain network by using defined policies, and to call ordering services to validate the endorsements and to incorporate the validated transactions into the blocks of the blockchain. The data stored in the blockchain is immutable; therefore, on-chain data are safeguarded from alteration. Additionally, in decentralized applications (DApps), smart contracts enable the analysis of accounts or transactions' status. The workflow of blockchain, IoT, and smart contracts has been demonstrated in Figure 4.

All the blockchain platforms allow smart contract programming to address the different business logic to support the fast-growing blockchain application. The Ethereum platform and Quorum, derived from

it, support smart contracts as Turing complete ones; Solidity and Serpent programming languages are compiled into Ethereum Virtual Machine byte codes. For the same reason, the EVM stores a record of the state change in the blockchain database. Hyperledger Fabric and Sawtooth are two famous platforms in the Hyperledger family, and they both support Golang, Java, Python, and JavaScript for smart contract development.

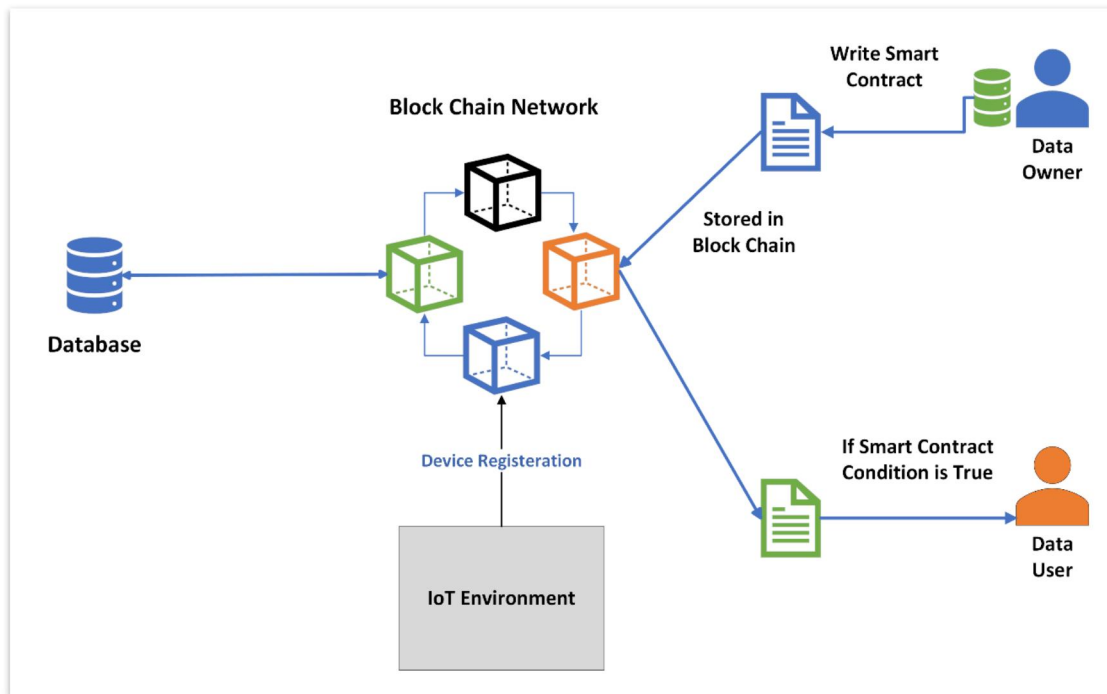

Figure 4: Integration of Smart contract with proposed IoT based sensor system

The steps followed are registering the devices and creation of smart contracts by uploading the sensor data of agriculture field data, storing the data, and accessing the data. These steps are explained in the following: These steps are explained in the following:

1. Device Registration: The IoT sensor device is then enrolled on the blockchain network and its identity is well established by storing an identifier for it.
 2. Smart Contract Development for Data Upload: An application smart contract is developed to enable the upload of data to the blockchain network from the device. The following are terms and conditions of the data upload; the person or the entity allowed to upload the data and the format of the data to be uploaded.
 3. Data Upload: The device owner sends information from the IoT sensor to the blockchain system. The data is first checked against precondition defined in the smart contract before storage can occur.
 4. Data Storage: The data collected is then validated and put on the blockchain network for a decentralized system. Blockchain technology guarantees that the data is stored in a distributed ledger that is spread across several computers, and cannot be altered.
 5. Data Access: When the data is put on the blockchain, it becomes retrievable by the permitted users. The rights of access to the data are also regulated by the smart contract, deciding who can take data from it.
3. Implementation and results

In the context of practical implementation of IoT sensor system in agricultural industries, blockchain is used in following manners such as applying required software, setting required parameters and creating smart contract. These steps include adding Wi-Fi, ether, MetaMask, Infura, and other required libraries,

creating packet SSL connections to Wi-Fi, checking the network information, and initializing Ethereum RPC nodes. After the setup has been made, the transactions are made, authorized and transmitted through a secure channel. The execution of these transactions is also assessed in terms of the energy required to perform the specific transaction. The result is, therefore, a very secure but at the same time integrated and efficient system of managing the various and sensitive data in the agriculture field.

The results comprise of fields such as TxHash, Block, Age, From, To, and Value in relation to the transactions. In Figure 5, the transactions for this study project have been demonstrated to be executed through ESP/NodemCU microcontroller for secure data transfer and for implementing the transfer of agricultural sensor data. These attributes are explained in the following:

1. Transaction Hash (TxHash): Transaction Hash (TxHash): This attribute is used in identifying a transaction on the blockchain and is unique to a specific transaction. It is a digital signature created by cryptographic hashing algorithms, which is used to refer the status and details of the transaction.
2. Block: The “Block” attribute identifies the block number at which the given transaction is incorporated. As for blockchains, the transactions are arranged in blocks, which are connected one to another sequentially. Identifying the block number helps in the location of the transaction within the structure of the blockchain.
3. Age: Age: This attribute defines the age of the transaction, namely the time elapsed from its confirmation and incorporation into a block. It provides information on the transaction’s frequency or infrequency.
4. From: The From attribute refers to the source or the sender of the transaction address. It defines the account or the entity that created and broadcasted the transaction throughout the blockchain network.
5. To: Describing the second party or the receiver’s end of the transaction, the To attribute captures the account or the receiver’s wallet that is to receive the specific cryptocurrency or digital asset being transacted.
6. Value: The Value attribute measures the value or the amount of the cryptocurrency, for example, Ether in Ethereum, used in the transaction. It defines the amount of digital currency used in the transaction, which supports monitoring financial operations and estimating their significance.

TxHash	Block	Age	From	To	Value	[Tx Fee]
0xb3c605006f31c85...	4019087	1 day 1 hr ago	0x6be1cb7b86b247...	0xf7a270b24d28590...	50 wei	0.0028218
0x4767291c40da13...	3992899	4 days 23 hrs ago	0x0cb37c147161d2...	0xf7a270b24d28590...	50 wei	0.0028218
0x7f5f997b72c6df8b...	3984772	6 days 4 hrs ago	0x6be1cb7b86b247...	0xf7a270b24d28590...	1 Ether	0.0028218
0x96dd5d7e574dd9...	3984770	6 days 4 hrs ago	0x6be1cb7b86b247...	0xf7a270b24d28590...	1 Ether	0.0041228
0xf53e934baffa401a...	3984761	6 days 4 hrs ago	0x6be1cb7b86b247...	0xf7a270b24d28590...	50 wei	0.0041228
0xc4d4fe8931daa99...	3984759	6 days 4 hrs ago	0x6be1cb7b86b247...	0xf7a270b24d28590...	50 wei	0.0028218
0x513c4dd475d6c3...	3984756	6 days 4 hrs ago	0x6be1cb7b86b247...	0xf7a270b24d28590...	50 wei	0.0041228
0x1b559efb8dfa47a...	3984754	6 days 4 hrs ago	0x6be1cb7b86b247...	0xf7a270b24d28590...	50 wei	0.0028218
0xdcbc9c2bb26f07b...	3984748	6 days 4 hrs ago	0x6be1cb7b86b247...	0xf7a270b24d28590...	50 wei	0.0028218
0x2a0fa150a98fb79...	3984746	6 days 4 hrs ago	0x6be1cb7b86b247...	0xf7a270b24d28590...	50 wei	0.0028218
0x695052c9a9936f1...	3984745	6 days 4 hrs ago	0x6be1cb7b86b247...	0xf7a270b24d28590...	50 wei	0.0028218
0x5f32a20d4d0804...	3984738	6 days 4 hrs ago	0x6be1cb7b86b247...	0xf7a270b24d28590...	50 wei	0.0028218
0x7dde1cb83e48c3...	3984676	6 days 4 hrs ago	0x6be1cb7b86b247...	0xf7a270b24d28590...	50 wei	0.0028218

Figure 5: Transactions through the Zerynth Ethereum module

Blockchain and IoT technologies are playing a new role in agriculture increased transparency, security, and efficiency. This discussion contrasts the findings of the studies with our experiment on an IoT-based system that intends to monitor agricultural parameters in real-time using blockchain. A comparison of current study with recent studies is presented in Table 1.

Table 1: Comparison of the current study with previous studies

Study	Year	Blockchain	IoT	Application Focus	Key Benefits
Proposed study	2024	Ethereum	Yes	Agriculture	Transparency, security, efficiency, real-time monitoring
El Mane et al.	2024	Ethereum	Yes	Agriculture	Security, efficiency
Hussien et al.	2023	Ethereum, Hyperledger	Yes	Healthcare	Security, data privacy, interoperability
Chaudhry et al.	2023	Ethereum	Yes	Smart cities	Real-time data sharing, security
Farooq et al.	2022	Hyperledger Fabric	Yes	Supply chain management	Traceability, transparency
Foti et al.	2021	IOTA	Yes	Environmental monitoring	Security, data integrity, cost reduction
Tripathi et al.	2021	MultiChain	Yes	Agriculture	Data integrity, transparency, decentralized control
Perera et al.	2020	Hyperledger Fabric	Yes	Food supply chain	Traceability, transparency, reduced fraud
Sharma et al.	2020	Ethereum	Yes	Smart grid	Data security, efficient energy management
Wang et al.	2019	Hyperledger Fabric	Yes	IoT device management	Security, access control, data integrity
Jamil et al.	2019	Ethereum, Hyperledger	Yes	Healthcare	Data privacy, security, improved patient care

The Figure 6 shows transactions over the time.

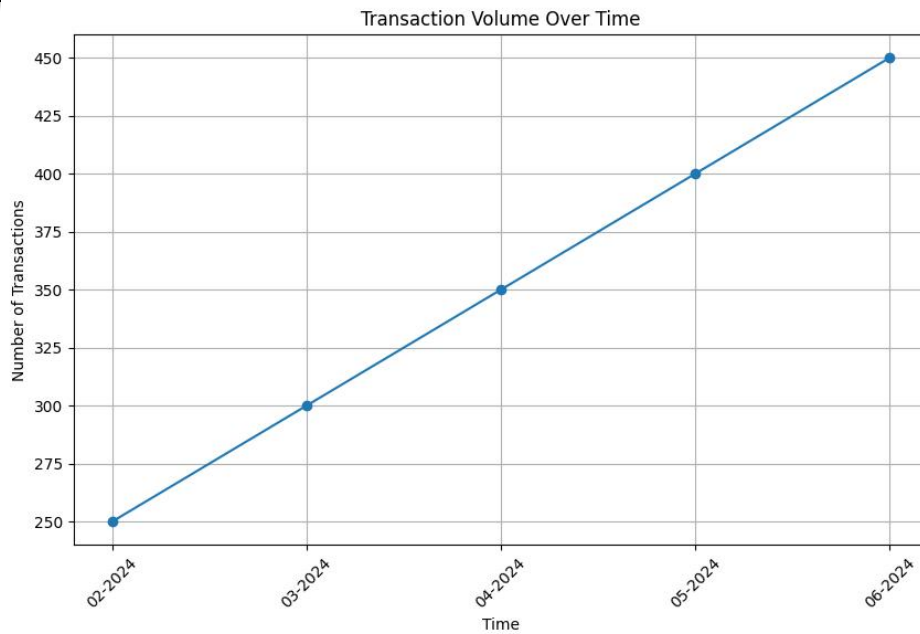

Figure 6: Transactions over the time

The Figure 7 shows energy consumed on every transaction over the time.

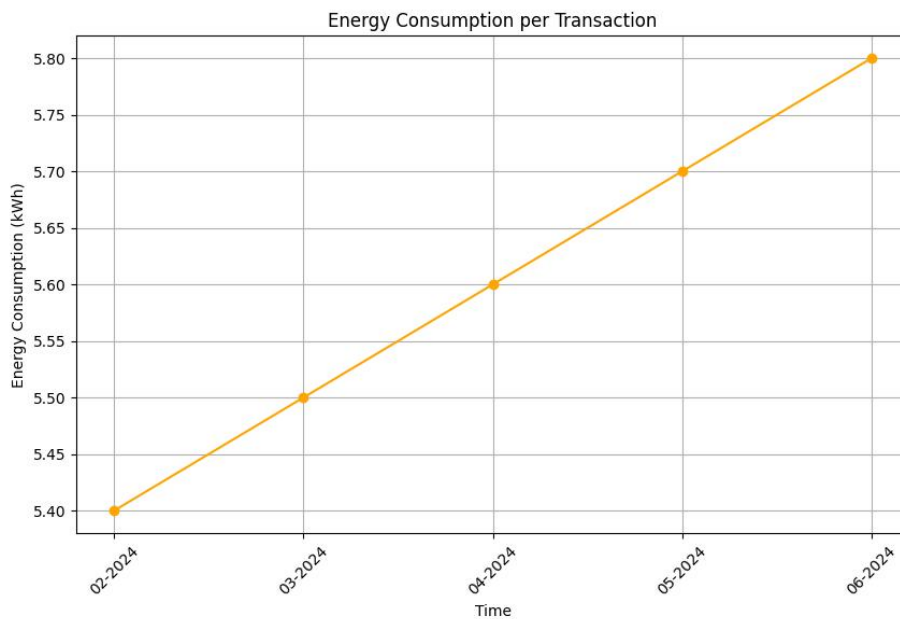

Figure 7: Transactions over the time Energy consumed over every transaction

The Figure 8 shows response time of system over the time period.

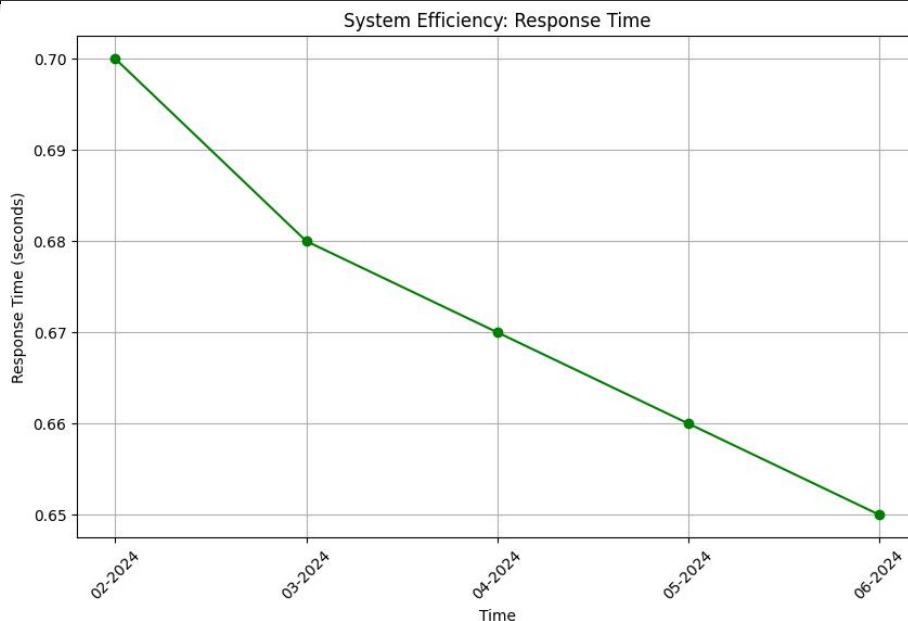

Figure 8: Response time of system over the time period

The Figure 9 shows data tempering attempts over the time period.

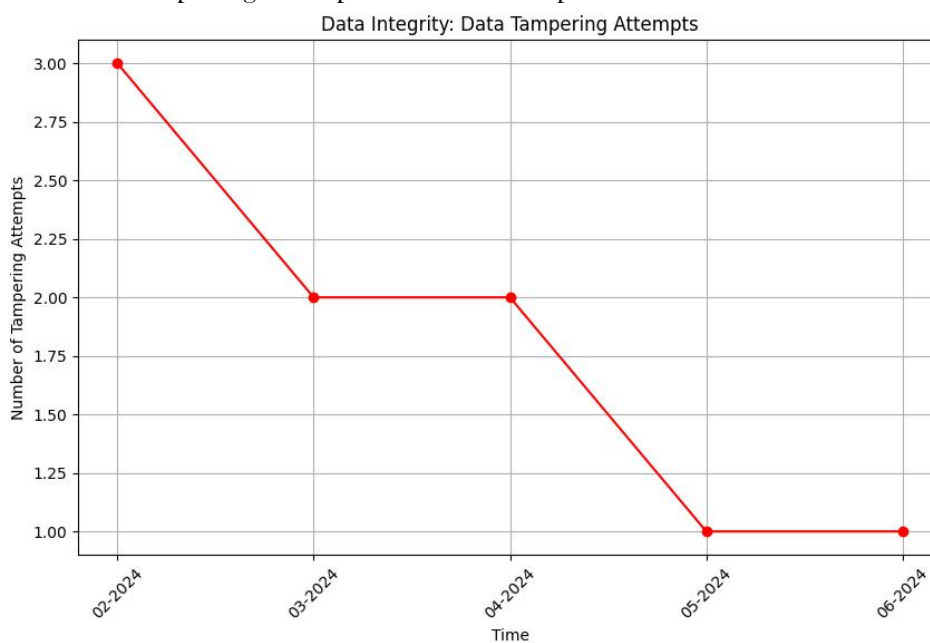

Figure 9: Tempering attempts over time

3.1. Discussion

The experiment developed an IoT system for measuring soil moisture and temperature and air temperature and humidity with DHT11, soil moisture sensors, and NodeMCU. This information is then transmitted through the internet to a server for the monitoring in real time using smart devices. Blockchain is integrated to enhance the general perception of the firm and the transparency to its stakeholders by documenting the records and tracking the origin of the items.

- **Device Registration and Smart Contract Development:** In IoT, every device is provided with a unique identification number in the blockchain, and code the smart contract to upload the data.
- **Data Upload and Storage:** Data gathered from the sensors are then transmitted to the blockchain, where the smart contracts verify it and then logs it.
- **Data Access:** For the stored data, the permissioned access can also be done by smart contracts for the authorized users.
- **Energy Consumption Measurement:** This is done before and after the transaction processes to check the energy being used.

4. Conclusion & Future Direction

Blockchain and IoT integration is therefore changing agriculture through the enhancement of the transparency, security and optimization. The particular experiment deals with the development of an IoT based system for Real-time monitoring of Agricultural parameters using blockchain. This experiment formed the system of soil moisture, air temperature, and humidity with the help of DHT11 sensors, soil moisture sensors, and NodeMCU microcontroller. The gathered information is transmitted through the Internet to a server for the possibility of real-time control using smart devices. It assists in offering safe data storage and the source of the product, which makes the clients rely on the product. As compared to the mentioned system, our system employs the actual environment monitoring; however, the introduction of such features as AI for the predictive analysis, trading platforms based on the blockchain, and safe channels for communication will significantly enhance the system. Several of the researches affirmed that the yields in crops, secure communication, robotic farming and efficient use of resources are possible by such technologies which makes a thought that while implementing such technologies there can be some benefits.

4.1. Future Direction

- **Expansion of Monitored Parameters:** The further development of the system should also incorporate more sensors to record other characteristics of the environment and give a general state of agriculture.
- **Integration of Predictive Analytics:** It is a fact that machine learning and AI can boost the predictive analysis and thus improve the ratio on crop yield and resources.
- **Scalability Solutions:** As for the points of increasing the scalability when there are more devices and data to incorporate, it is necessary to mention that the corresponding approaches should be improved. This may for instance be the case as in the search for enhanced architectures of blockchain or a search for a combination of the two.
- **Enhanced Privacy Measures:** There can be other measures to enhance the privacy; such as the application of other technologies that would assist in concealing the identity of the users within the context of the given blockchain network, for instance, the application of zero-knowledge proof.
- **Energy Optimization:** In the future, for the blockchain to be sustainable, it would be important to find how to make the energy used in the transactions within the system to be less for instance consensus algorithms that do not use a lot of energy.

- Blockchain-Based Trading Platforms: Thus, the application of blockchain technologies when creating trading platforms will enable the farmers to address the issue of market entry, as well as the optimization of economic performance indicators of agricultural production and the efficiency of the supply chain.
- Real-Time Security Monitoring: Implementation of cloud-enabled security monitoring frameworks can enhance the real-time monitoring of security threats that affect the farm data thus enhancing security. To identify the directions of development and to outline the opportunities of the further improvement of the integration between blockchain and IoT in agriculture, it is necessary to indicate the following directions.

REFERENCES

1. Hekmat, A., et al., Brain tumor diagnosis redefined: Leveraging image fusion for MRI enhancement classification. *Biomedical Signal Processing and Control*, 2025. 109: p. 108040.
2. O. Bilal, Asif Raza, S. ur R. Khan, and Ghazanfar Ali, "A Contemporary Secure Microservices Discovery Architecture with Service Tags for Smart City Infrastructures ", *VFAST trans. softw. eng.*, vol. 12, no. 1, pp. 79-92, Mar. 2024
3. M. Waqas, Z. Khan, S. U. Ahmed and Asif. Raza, "MIL-Mixer: A Robust Bag Encoding Strategy for Multiple Instance Learning (MIL) using MLP-Mixer," 2023 18th International Conference on Emerging Technologies (ICET), Peshawar, Pakistan, 2023, pp. 22-26.
4. Khan, M.A., Khan, S.U.R. & Lin, D. Shortening surgical time in high myopia treatment: a randomized controlled trial comparing non-OVD and OVD techniques in ICL implantation. *BMC Ophthalmol* 25, 303 (2025). <https://doi.org/10.1186/s12886-025-04135-3>
5. Mahmood, F., Abbas, K., Raza, A., Khan, M.A., & Khan, P.W. (2019). Three Dimensional Agricultural Land Modeling using Unmanned Aerial System (UAS). *International Journal of Advanced Computer Science and Applications (IJACSA)* [p-ISSN : 2158-107X, e-ISSN : 2156-5570], 10(1).
6. Waqas, M., Bandyopadhyay, R., Showkatian, E., Muneer, A., Zafar, A., Alvarez, F. R., ... & Wu, J. (2025). The Next Layer: Augmenting Foundation Models with Structure-Preserving and Attention-Guided Learning for Local Patches to Global Context Awareness in Computational Pathology. *arXiv preprint arXiv:2508.19914*.
7. Khan, U. S., Ishfaq, M., Khan, S. U. R., Xu, F., Chen, L., & Lei, Y. (2024). Comparative analysis of twelve transfer learning models for the prediction and crack detection in concrete dams, based on borehole images. *Frontiers of Structural and Civil Engineering*, 1-17.
8. Bilal, Omair, Arash Hekmat, Inzamam Shahzad, Asif Raza, and Saif Ur Rehman Khan. "Boosting Machine Learning Accuracy for Cardiac Disease Prediction: The Role of Advanced Feature Engineering and Model Optimization." *The Review of Socionetwork Strategies* (2025): 1-30.
9. Khan, S. U. R., & Khan, Z. (2025). Detection of Abnormal Cardiac Rhythms Using Feature Fusion Technique with Heart Sound Spectrograms. *Journal of Bionic Engineering*, 1-20.
10. Khan, Saif Ur Rehman, Asif Raza, Inzamam Shahzad, and Ghazanfar Ali. "Enhancing concrete and pavement crack prediction through hierarchical feature integration with VGG16 and triple classifier ensemble." In *2024 Horizons of Information Technology and Engineering (HITE)*, pp. 1-6. IEEE, 2024.
11. Muneer, A., Waqas, M., Saad, M. B., Showkatian, E., Bandyopadhyay, R., Xu, H., ... & Wu, J. (2025). From Classical Machine Learning to Emerging Foundation Models: Review on Multimodal Data Integration for Cancer Research. *arXiv preprint arXiv:2507.09028*.
12. Khan, S.U.R., Asif, S., Bilal, O. et al. Lead-cnn: lightweight enhanced dimension reduction convolutional neural network for brain tumor classification. *Int. J. Mach. Learn. & Cyber.* (2025). <https://doi.org/10.1007/s13042-025-02637-6>.

13. Khan, Z., Hossain, M. Z., Mayumu, N., Yasmin, F., & Aziz, Y. (2024, November). Boosting the Prediction of Brain Tumor Using Two Stage BiGait Architecture. In 2024 International Conference on Digital Image Computing: Techniques and Applications (DICTA) (pp. 411-418). IEEE.
14. Sur R. Khan, Asif. Raza, Muhammad Tanveer Meeran, and U. Bilhaj, "Enhancing Breast Cancer Detection through Thermal Imaging and Customized 2D CNN Classifiers", VFAST trans. softw. eng., vol. 11, no. 4, pp. 80-92, Dec. 2023.
15. Waqas, M., Tahir, M. A., AlMaadeed, S., Bouridane, A., & Wu, J. (2024). Simultaneous instance pooling and bag representation selection approach for multiple-instance learning (MIL) using vision transformer. *Neural Computing and Applications*, 36(12), 6659-6680.
16. Khan, S. U. R., Asif, S., Zhao, M., Zou, W., Li, Y., & Xiao, C. (2026). ShallowMRI: A novel lightweight CNN with novel attention mechanism for Multi brain tumor classification in MRI images. *Biomedical Signal Processing and Control*, 111, 108425.
17. Khan, M. A., Khan, S. U. R., Rehman, H. U., Aladhadh, S., & Lin, D. (2025). Robust InceptionV3 with Novel EYENET Weights for DiEYENET Ocular Surface Imaging Dataset: Integrating Chain Foraging and Cyclone Aging Techniques. *International Journal of Computational Intelligence Systems*, 18(1), 1-26.
18. Khan, U. S., & Khan, S. U. R. (2025). Ethics by Design: A Lifecycle Framework for Trustworthy AI in Medical Imaging From Transparent Data Governance to Clinically Validated Deployment. arXiv preprint arXiv:2507.04249.
19. Khan, S. U. R., Asif, S., Zhao, M., Zou, W., Li, Y., & Xiao, C. (2026). ShallowMRI: A novel lightweight CNN with novel attention mechanism for Multi brain tumor classification in MRI images. *Biomedical Signal Processing and Control*, 111, 108425.
20. Waqas, M., Tahir, M. A., & Qureshi, R. (2023). Deep Gaussian mixture model based instance relevance estimation for multiple instance learning applications. *Applied intelligence*, 53(9), 10310-10325.
21. Al-Khasawneh, M. A., Raza, A., Khan, S. U. R., & Khan, Z. (2024). Stock Market Trend Prediction Using Deep Learning Approach. *Computational Economics*, 1-32.
22. HUSSAIN, S., Raza, A., MEERAN, M. T., IJAZ, H. M., & JAMALI, S. (2020). Domain Ontology Based Similarity and Analysis in Higher Education. *IEEEP New Horizons Journal*, 102(1), 11-16.
23. Khan, S.U.R., Zhao, M. & Li, Y. Detection of MRI brain tumor using residual skip block based modified MobileNet model. *Cluster Comput* 28, 248 (2025). <https://doi.org/10.1007/s10586-024-04940-3>
24. Raza, A., & Meeran, M. T. (2019). Routine of Encryption in Cognitive Radio Network. *Mehran University Research Journal of Engineering and Technology* [p-ISSN: 0254-7821, e-ISSN: 2413-7219], 38(3), 609-618.
25. Khan, S. U. R., Asim, M. N., Vollmer, S., & Dengel, A. (2025). FloraSyntropy-Net: Scalable Deep Learning with Novel FloraSyntropy Archive for Large-Scale Plant Disease Diagnosis. arXiv preprint arXiv:2508.17653.
26. Meeran, M. T., Raza, A., & Din, M. (2018). Advancement in GSM Network to Access Cloud Services. *Pakistan Journal of Engineering, Technology & Science* [ISSN: 2224-2333], 7(1).
27. Khan, S. U. R., Rehman, H. U., & Bilal, O. (2025). AI-powered cancer diagnosis: classifying viable (live) vs non-viable (dead) cells using transfer learning. *Signal, Image and Video Processing*, 19(15), 1326.
28. Bilal, O., Hekmat, A., Shahzad, I. et al. Boosting Machine Learning Accuracy for Cardiac Disease Prediction: The Role of Advanced Feature Engineering and Model Optimization. *Rev Socionetwork Strat* (2025). <https://doi.org/10.1007/s12626-025-00190-w>

29. Asif Raza, Inzamam Shahzad, Ghazanfar Ali, and Muhammad Hanif Soomro. "Use Transfer Learning VGG16, Inception, and Resnet50 to Classify IoT Challenge in Security Domain via Dataset Bench Mark." *Journal of Innovative Computing and Emerging Technologies* 5, no. 1 (2025).
30. Khan, M. A., Khan, S. U. R., Rehman, H. U., Aladhadh, S., & Lin, D. (2025). Robust InceptionV3 with Novel EYENET Weights for Di-EYENET Ocular Surface Imaging Dataset: Integrating Chain Foraging and Cyclone Aging Techniques. *International Journal of Computational Intelligence Systems*, 18(1), 204.
31. Khan, Z., Khan, S. U. R., Bilal, O., Raza, A., & Ali, G. (2025, February). Optimizing Cervical Lesion Detection Using Deep Learning with Particle Swarm Optimization. In *2025 6th International Conference on Advancements in Computational Sciences (ICACS)* (pp. 1-7). IEEE.
32. Raza, Asif, Inzamam Shahzad, Muhammad Salahuddin, and Sadia Latif. "Satellite Imagery Employed to Analyze the Extent of Urban Land Transformation in The Punjab District of Pakistan." *Journal of Palestine Ahliya University for Research and Studies* 4, no. 2 (2025): 17-36.
33. Khan, S. U. R., Asif, S., Zhao, M., Zou, W., Li, Y., & Li, X. (2025). Optimized deep learning model for comprehensive medical image analysis across multiple modalities. *Neurocomputing*, 619, 129182.
34. Asif Raza, Salahuddin, Ghazanfar Ali, Muhammad Hanif Soomro, Saima Batool, "Analyzing the Impact of Artificial Intelligence on Shaping Consumer Demand in E-Commerce: A Critical Review", *International Journal of Information Engineering and Electronic Business(IJIEEB)*, Vol.17, No.5, pp. 42-61, 2025. DOI:10.5815/ijieeb.2025.05.04
35. Li, Wentao, Amgad Muneer, Muhammad Waqas, Xiaobo Zhou, and Jia Wu. "Attention-Fusion Model for Multi-omics (AMMO) Data Integration in Lung Adenocarcinoma." In *International Workshop on Computational Mathematics Modeling in Cancer Analysis*, pp. 52-60. Cham: Springer Nature Switzerland, 2024.
36. Khan, S.U.R., Raza, A., Shahzad, I., Khan, S. U. R. (2025). Subcellular Structures Classification in Fluorescence Microscopic Images. In: Arif, M., Jaffar, A., Geman, O. (eds) *Computing and Emerging Technologies. ICCET 2023. Communications in Computer and Information Science*, vol 2056. Springer, Cham. https://doi.org/10.1007/978-3-031-77620-5_20
37. Maqsood, H., & Khan, S. U. R. (2025). MeD-3D: A Multimodal Deep Learning Framework for Precise Recurrence Prediction in Clear Cell Renal Cell Carcinoma (ccRCC). arXiv preprint arXiv:2507.07839.
38. Khan, S. U. R., Asif, S., Zhao, M., Zou, W., & Li, Y. (2025). Optimize brain tumor multiclass classification with manta ray foraging and improved residual block techniques. *Multimedia Systems*, 31(1), 1-27.
39. Raza, A., Salahuddin, & Inzamam Shahzad. (2024). Residual Learning Model-Based Classification of COVID-19 Using Chest Radiographs. *Spectrum of Engineering Sciences*, 2(3), 367-396.
40. Khan, S. U. R., Asif, S., & Bilal, O. (2025). Ensemble Architecture of Vision Transformer and CNNs for Breast Cancer Tumor Detection From Mammograms. *International Journal of Imaging Systems and Technology*, 35(3), e70090.
41. Raza, A., Soomro, M. H., Shahzad, I., & Batool, S. (2024). Abstractive Text Summarization for Urdu Language. *Journal of Computing & Biomedical Informatics*, 7(02).
42. Hekmat, A., Zuping, Z., Bilal, O., & Khan, S. U. R. (2025). Differential evolution-driven optimized ensemble network for brain tumor detection. *International Journal of Machine Learning and Cybernetics*, 1-26.

43. Rehman, Laiba, Humera Batool Gill, Sohaib Ahmad, and Ezza Irshad. "FROM MOLECULES TO MIND: SIMULATING THE FUTURE OF DATA STORAGE WITH DNA, GRAPHENE AND NEURAL ENCODING." *Kashf Journal of Multidisciplinary Research* 2, no. 10 (2025): 45-60.
44. Waqas, M., Ahmed, S. U., Tahir, M. A., Wu, J., & Qureshi, R. (2024). Exploring multiple instance learning (MIL): A brief survey. *Expert Systems with Applications*, 250, 123893.
45. Khan, S. U. R. (2025). Multi-level feature fusion network for kidney disease detection. *Computers in Biology and Medicine*, 191, 110214.
46. Khan, S. R., Asif Raza, Inzamam Shahzad, & Hafiz Muhammad Ijaz. (2024). Deep transfer CNNs models performance evaluation using unbalanced histopathological breast cancer dataset. *Lahore Garrison University Research Journal of Computer Science and Information Technology*, 8(1).
47. Aslam, N., Meeran, M. T., Aslam, M., Maqbool, M. S., & Saeed, B. (2025). UNDERSTANDING URBAN EXPANSION THROUGH MULTI-TEMPORAL SATELLITE DATA ANALYSIS. *Kashf Journal of Multidisciplinary Research*, 2(09), 252-273.
48. Hiyat, Muhammad, Muhammad Usama Javed, Maria Akhtar, and Muhammad Tanveer Meeran. "A NOVEL SEMI-SUPERVISED FRAMEWORK FOR CYBERSECURITY THREAT DETECTION IN WIRELESS SENSOR NETWORKS." *Kashf Journal of Multidisciplinary Research* 2, no. 10 (2025): 1-16.
49. Bilal, O., Hekmat, A., & Khan, S. U. R. (2025). Automated cervical cancer cell diagnosis via grid search-optimized multi-CNN ensemble networks. *Network Modeling Analysis in Health Informatics and Bioinformatics*, 14(1), 67.
50. Asim, M. N., Ibrahim, M. A., Malik, M. I., Dengel, A., & Ahmed, S. (2022). LGCA-VHPPI: A local-global residue context aware viral-host protein-protein interaction predictor. *Plos one*, 17(7), e0270275.
51. Khan, S. U. R., Asim, M. N., Vollmer, S., & Dengel, A. (2025). Robust & precise knowledge distillation-based novel context-aware predictor for disease detection in brain and gastrointestinal. *arXiv preprint arXiv:2505.06381*.
52. N. Mayumu, D. Xiaoheng, P. Mukala, S. U. R. Khan and M. U. Saeed, "Omni-V2X: A Vision-Language Model for Actionable Insights in Vehicle-to-Everything Systems," 2025 International Joint Conference on Neural Networks (IJCNN), Rome, Italy, 2025, pp. 1-8, doi: 10.1109/IJCNN64981.2025.11228491.
53. Wasim, M., Mahmood, W., Asim, M. N., & Khan, M. U. (2018). Multi-label question classification for factoid and list type questions in biomedical question answering. *IEEE Access*, 7, 3882-3896.
54. Khalid, Ariba, Muhammad Usama Javed, Muhammad Tanveer Meeran, Naeem Aslam, and Muhammad Fuzail. "TOWARDS SAFE AND SECURE URBAN TRANSPORTATION INTRUSION DETECTION SYSTEM FOR CONNECTED VEHICLES IN SMART CITIES." *Kashf Journal of Multidisciplinary Research* 2, no. 10 (2025): 17-35.
55. Yang, H., Khan, S. U. R., Bilal, O., Chen, C., & Zhao, M. (2025). CEOE-Net: Chaotic Evolution Algorithm-Based Optimized Ensemble Framework Enhanced with Dual-Attention for Alzheimer's Diagnosis. *Computer Modeling in Engineering & Sciences*, 145(2), 2401.
56. S. Ur Rehman Khan, O. Bilal, S. Mistry, N. Deb, M. Mahmud and M. Bhuyan, "KDLight: A Lightweight Knowledge Distillation Framework for Medical Image Classification," 2025 International Joint Conference on Neural Networks (IJCNN), Rome, Italy, 2025, pp. 1-8, doi: 10.1109/IJCNN64981.2025.11228615.
57. O. Bilal, S. Ur Rehman Khan, S. Mistry, N. Deb, M. Mahmud and M. Bhuyan, "Towards Efficient Pruning and Multi-Scale Feature Transformations to Uncover Medical Diseases," 2025 International Joint Conference on Neural Networks (IJCNN), Rome, Italy, 2025, pp. 1-8, doi: 10.1109/IJCNN64981.2025.11229047.

